

Air purification

InspirAIR® Home

Air purification for individual dwellings



Intervention guide

Version - March 2019

Description	■
Exploded views and Parts	■
Electrical wiring diagrams	■
Maintenance instructions	■
Repair guide	■



Contents

1. General information	4
1.1 Related reference documents	4
2. General description	4
2.1 InspirAIR® Home Heat recovery ventilation system	4
2.2 Typical example	4
2.3 Product references and kit contents	5
3. Exploded view and parts list	6
3.1 Exploded view (Version 240/370 Premium right)	6
3.2 Exploded view (Version 150 Premium right)	7
3.3 Spare parts list	7
3.4 Options & Accessories	10
4. Electrical wiring diagrams	12
5. Maintenance instructions	13
<i>Definition of maintenance levels</i>	13
<i>List of tools and equipment</i>	13
<i>Maintenance operations guide</i>	13
5.1 List of preventive maintenance operations InspirAir 240/370	14
5.2 List of curative maintenance operations InspirAir 240/370	14
5.3 Operating procedures Inspirair 240/370	15
5.4 List of preventive maintenance operations InspirAir 150	22
5.5 List of curative maintenance operations InspirAir 150	22
5.6 Operating procedures Inspirair 150	24
5.7 Repair guide	32
5.5 Breakdown flow chart	33

1. General information

1.1 Related reference documents

Document title	Reference
Installation and maintenance guide	11029515
Use and servicing manual	11027565
Classic keypad navigation manual	11027566
Premium keypad navigation manual	11027542
InspirAIR Home SC Modbus manual	11024829

2. General description

2.1 InspirAIR® Home Heat recovery ventilation system

In a heat recovery system, air is renewed mechanically through a supply into living areas and exhaust from utility rooms (kitchen, bathroom/shower, WC, cellar)

The soiled air extracted by the utility room outlets pass through a heat recovery unit before being discharged outside.

The heat exchanger serves to recover the heat in the exhaust air to pre-heat the incoming air.



2.2 Typical example

There are two possible installations:



Ceiling mounting



Wall mounting

2.3 Product references and kit contents

Description	Side	InspirAIR® Home Classic	InspirAIR® Home Modbus	InspirAIR® Home Premium
InspirAIR® Home SC150	Right	11023453	11023457	11023455
	Left	11023454	11023458	11023456
InspirAIR® Home SC240	Right	11023310	11023446	11023312
	Left	11023311	11023447	11023313
InspirAIR® Home SC370	Right	11023314	11023448	11023316
	Left	11023315	11023449	11023317



- Fresh air
- Exhaust air
- Extract air
- Supply air

3.Exploded view and parts list

3.1 Exploded view (Version 240/370 Premium right)

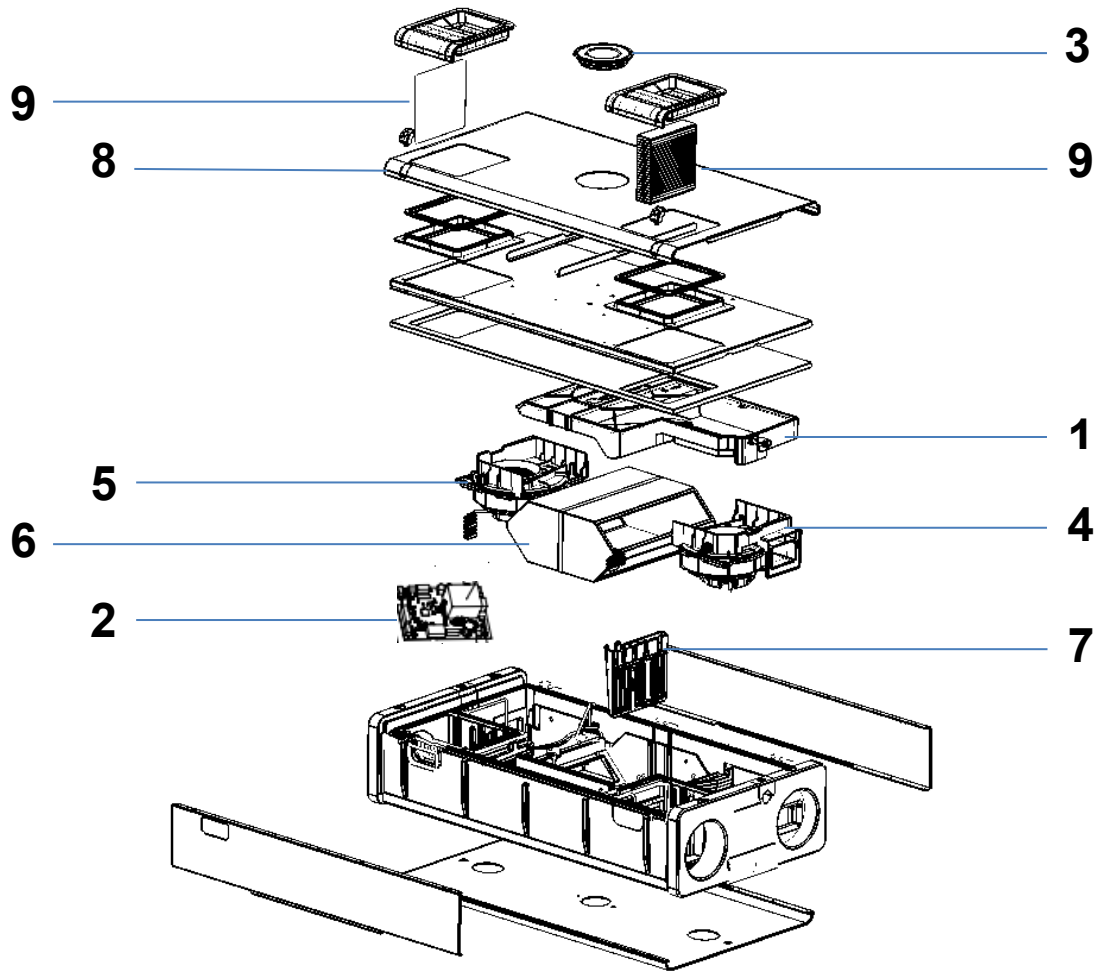

3.2 Exploded view (Version 150 Premium right)

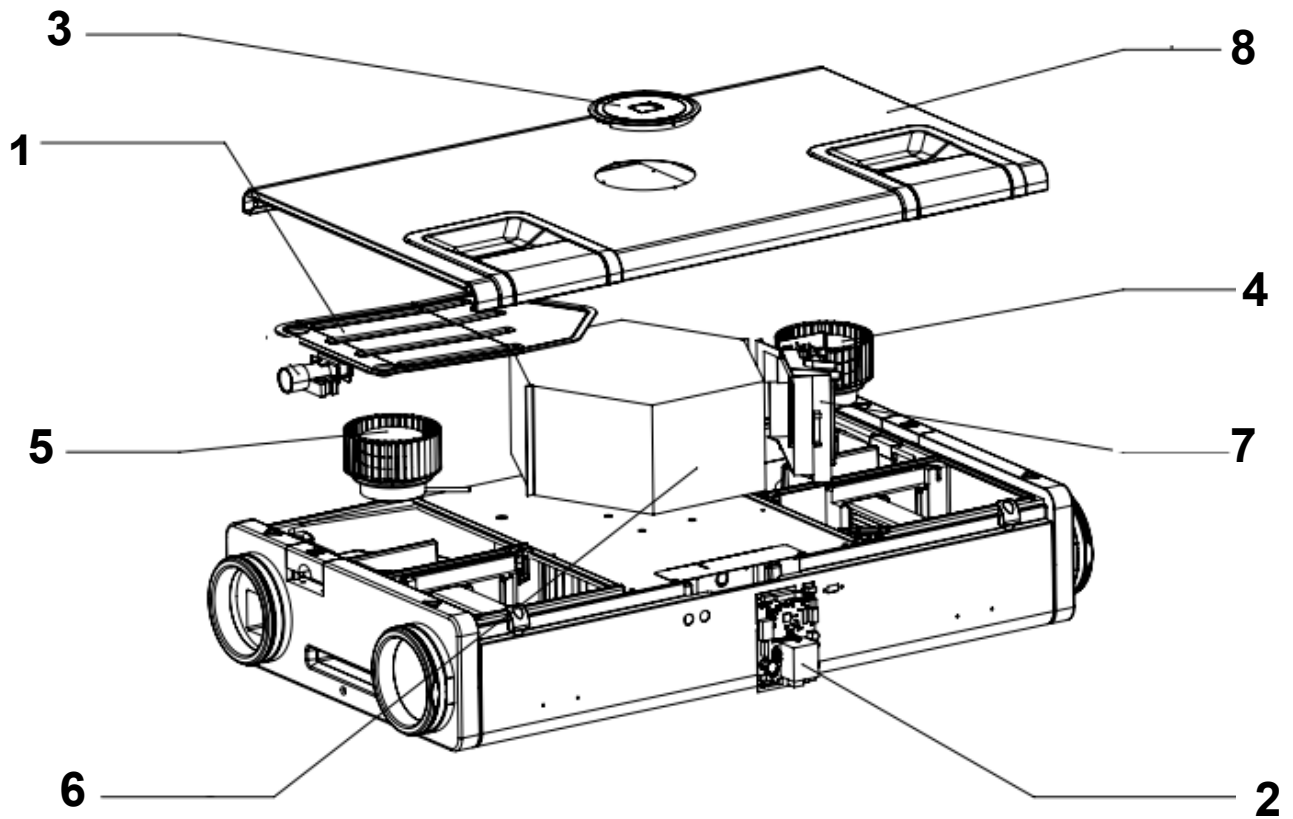

3.3 Spare parts list

Reference	Description	Reference	Classic	Modbus	Premium
1	S/E CONDENSATE TRAY SC150	11100764	OK	OK	OK
	CONDENSATE TRAY SC240 RIGHT	11127734	OK	OK	OK
	CONDENSATE TRAY SC240 LEFT	11127733	OK	OK	OK
	CONDENSATE TRAY SC370 RIGHT	11127663	OK	OK	OK
	CONDENSATE TRAY SC370 LEFT	11127662	OK	OK	OK

Reference	Description	Reference	Classic	Modbus	Premium
2	S/E ELEC. BOARD SC150	11100765	OK	-	-
		11100766	-	OK	OK
	ELEC. BOARD SC240	11127578	OK	-	-
		11127579	-	OK	OK
	ELEC. BOARD SC370	11100521	OK	-	-
		11100522	-	OK	OK
3	S/E CORE (V2) SC150 / SC240/ SC370	11100771	-	-	OK
4	S/E Clockwise Motor SC150	11100759	OK	OK	OK
	S/E Clockwise Motor SC240	11127750	OK	OK	OK
	S/E Clockwise Motor SC370	11127679	OK	OK	OK
5	S/E ANTI-CLOCKWISE MOTOR SC150	11100760	OK	OK	OK
	S/E ANTI-CLOCKWISE MOTOR SC240	11127745	OK	OK	OK
	S/E ANTI-CLOCKWISE MOTOR SC370	11127674	OK	OK	OK



Reference	Description	Reference	Classic	Modbus	Premium
6	INSPIRAIR SC150 HEAT EXCHANGER	11100772	OK	OK	OK
	S/E HEAT EXCHANGER SC240	11127719	OK	OK	OK
	S/E HEAT EXCHANGER SC370	11127696	OK	OK	OK
7	S/E BY-PASS SC150	11100763	OK	OK	OK
	S/E BY-PASS SC240	11127766	OK	OK	OK
	S/E BY-PASS SC370	11127695	OK	OK	OK
8	S/E COVER SC150	11100768	OK	OK	-
		11100769	-	-	OK
	COVER SC240	11127759	OK	OK	-
		11127760	-	-	OK
	COVER SC370	11127688	OK	OK	-
		11127689	-	-	OK
9	Please refer to the user manual for the filters				
-	INSTALL. KEYPAD SC240/SC370 RIGHT	11127577	OK	OK	-
	INSTALL. KEYPAD SC150/SC240/SC370 LEFT	11127563	OK	OK	-
-	COMPLETE HARNESS KIT SC150	11100767	OK	OK	OK
	COMPLETE HARNESS KIT SC240/370	11127599	OK	OK	OK

3.4 Options & Accessories

⇒ Filters: please refer to the user manual or the Aldes website

Product	Description	InspirAIR® Home SC150	InspirAIR® Home SC240	InspirAIR® Home SC370
	"Blind" finishing trap	11023321	11023321	11023321
	"Porthole" finishing trap	11023440	11023440	11023440
	Cradle	11023322	11023322	11023322
	Distribution box fan	-*	11023323	11023327
	Duct cover	-	300mm 11023324	300mm 11023328
		-	500mm 11023398	500mm 11023399
		-	Finish 11023426	Finish 11023427
	Bahia Curve terminals	11015490	11015490	11015490
	BCA Bus pre-heating coil	11023225	11023225	11023225
	CO2 sensor	11017090	11017090	11017090
	Calogaine seal connector D160	Built in	11023209	11023209
	Male galvanised connector with seals	-	11098163	11098163
	AldesConnectBoxTM	11023386	11023386	11023386
	2-speed remote control - push button (wired)	11026011	11026011	11026011

*Possibility of using the SC370 version as centre-to-centre distance of connections identical but outside dimensions greater.

Product	Description	InspirAIR® Home SC150	InspirAIR® Home SC240	InspirAIR® Home SC370
	3-speed remote control (wired)	11023065	11023065	11023065
	4-speed remote control (wired)	11023334	11023334	11023334

4. Electrical wiring diagrams

Inspirair home SC150 Classic, SC240 Classic and SC370 Classic board:

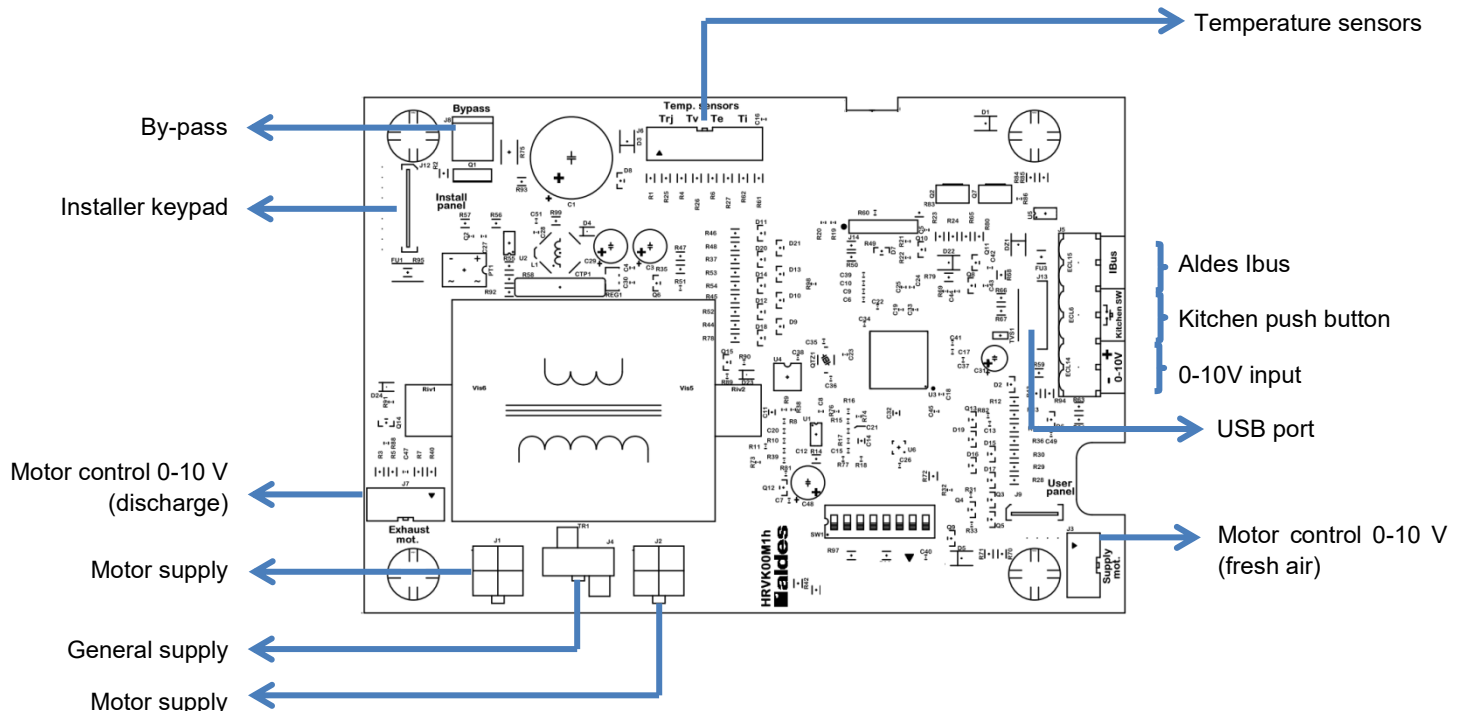

Inspirair home SC150 Premium / Modbus; SC240 Premium / Modbus et SC370 Premium / Modbus board:

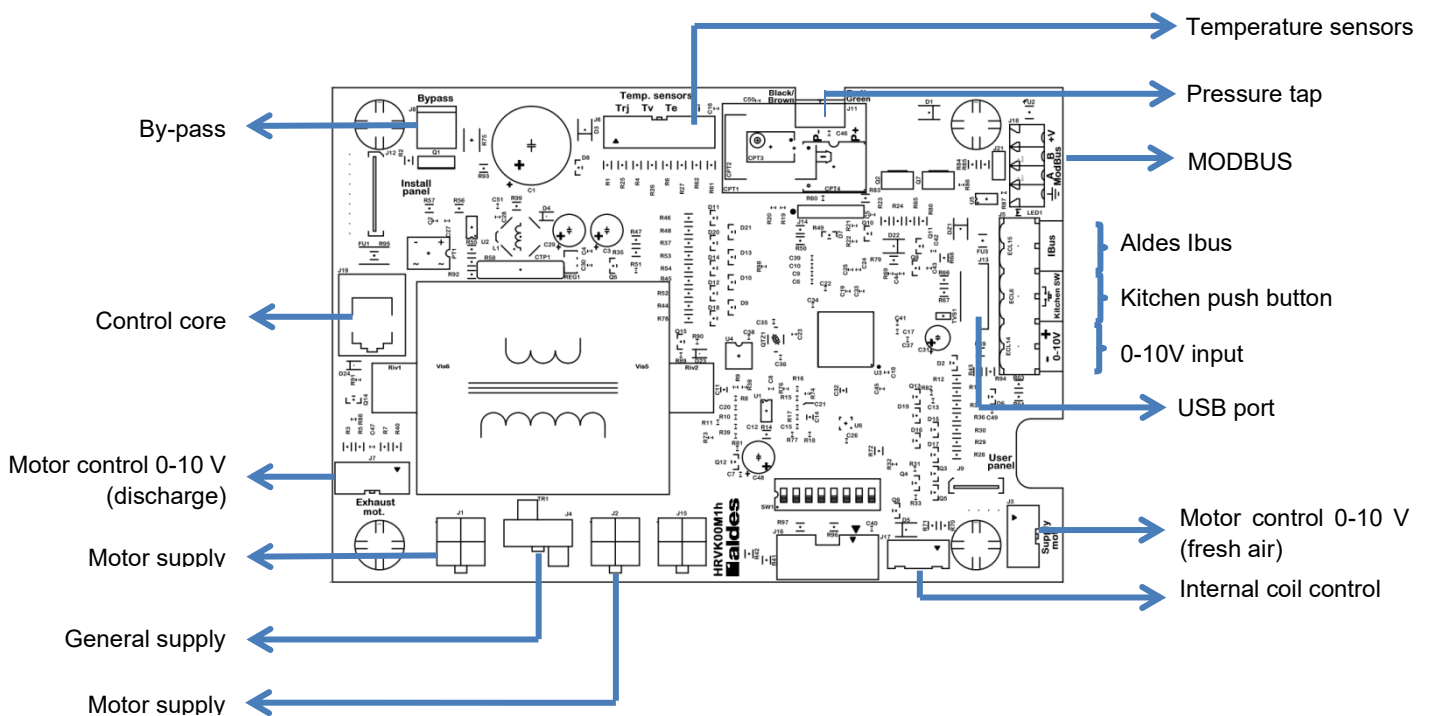

5. Maintenance instructions

- Check that the installation complies with the recommendations provided ("**Installation Manual**")
- Check that the unit is configured to suit the installation ("**Configuration Manual**")
- Check that all exhaust ducts and terminals are correctly connected. Flexible ducts must be taut and not crushed.

Definition of maintenance levels

Maintenance level	Definition	Lowest level of intervention
1	Simple actions required for operations, carried out on easily accessible elements in complete safety	Occupant of the premises
2	Actions requiring simple procedures	Unapproved tradesman
3	Actions requiring complex procedures	Approved tradesman

⇒ Here maintenance levels 2 and 3 are similar, as no maintenance operation requires specific qualification.

List of tools and equipment

- ➔ USB key to recover history and updates
- ➔ Standard tools
- ➔ Reflashing software

Maintenance operations guide

The maintenance operations guide below presents all preventive and corrective maintenance tasks identified for product servicing and repairs. Each task presented within the guide is referenced and detailed in the Operating Instructions paragraph of this document.

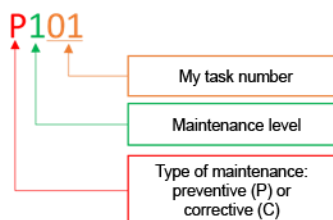

Caution: the following operating procedures have been carried out on a left-hand model (see paragraph 2.3) and the electronic board is therefore on the right

5.1 List of preventive maintenance operations InspirAir 240/370

P-101			
		Filter replacement	
Filters	Nbr.: 3(+)	Frequency: every nine months	5min.
List of steps: - Step 4			

P-201			
		Cleaning the heat exchanger	
Heat exchanger	Nbr.: : 1	Frequency: every two years	1h
List of steps: - Step 1; 2; 3; 9; 10			

5.2 List of curative maintenance operations InspirAir 240/370

C-201			
		Motor replacement	
Motor	Nbr.: 1	Standard tools	45min.
List of steps: - Step 1; 2; 3; 5			

C-202			
		Electronic board replacement	
Elec. board	Nbr.: 1	Standard tools	45min.
List of steps: - Step 1; 6; 12			

C-203			
		By-pass replacement	
By-pass	Nbr.: 1	Standard tools	45min.
List of steps: - Step 1; 2; 7			

C-204			
		Sensor replacement	
Sensors	Nbr.: 1	Standard tools	45min.
List of steps: - Step 1; 2; 3; 8			

C-205			
		Core replacement	
Core	Nbr.: 1	Standard tools	30min.
List of steps: - Step 1; 2; 11			

C-206			
		Reflash the regulator	
-	-	Standard tools and USB key + software	30min
List of steps: - Step 12			

5.3 Operating procedures Inspirair 240/370

Step No. 1		
	<i>Switch the unit off</i>	
		- Switch the unit off using the electrical cabinet circuit breaker.

Step No. 2		
	<i>Open the door</i>	
		<ul style="list-style-type: none"> - Remove the filter plugs - Remove the two fastening screws on the door giving access to the equipment's internal components

Step No. 3



Remove the condensate tray

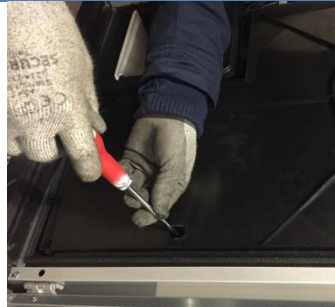
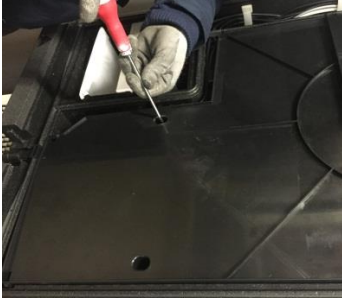

Version without strap

- Remove the two tray fastening screws







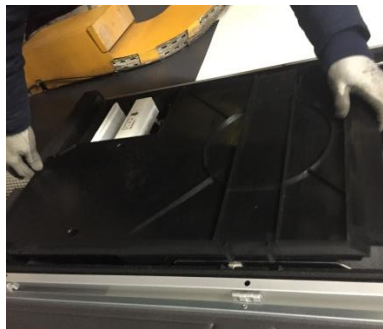



Version with strap

- Remove the holding strap



- Remove the plug protecting the discharge of condensates
- Unplug the condensate discharge pipe
- Extract the tray

Step No. 4		
	<p>Change the filters (right-hand version here)</p>	
		<ul style="list-style-type: none"> - Open the access hatches to the filters and electronic box - Remove the filters
	-	<ul style="list-style-type: none"> - Insert the new filters - Watch out for the fitting direction for the pollen filters: the arrow must point in the same direction as the one of the box fan

Step No. 5		
	<p>Replace a motor</p> <p style="color: red; font-weight: bold;">⚠ Caution: the two motors are different.</p>	
		<ul style="list-style-type: none"> - Remove the sensor fixed to the motor - Disconnect the motor from the electronic board (see paragraph 4)
		<ul style="list-style-type: none"> - Remove the two screws fastening the motor to the base frame - Carefully remove the motor. - Insert the new motor and reverse the steps to refit it

Step No. 6



Replace the electronic board

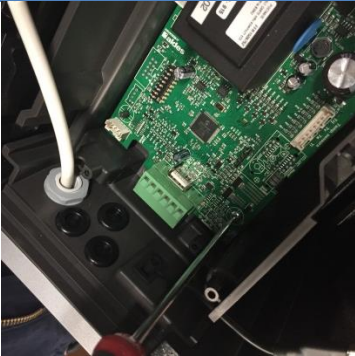

- Unplug all connectors from the board
- Remove the two fastening screws
- Fix the new board
- Plug the connectors back in following the drawing in paragraph 4

Step No. 7



Replace the by-pass (thermal cylinder)

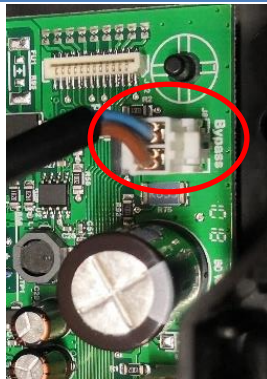
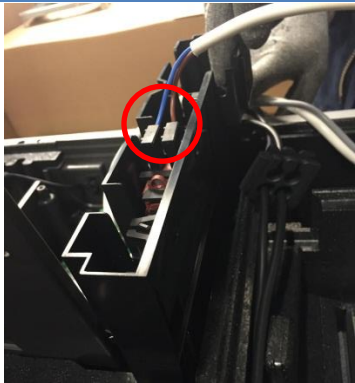

- Unplug the thermal cylinder connections
- Remove the cylinder carefully from its housing
- Insert the new cylinder and plug in the connections

Step No. 8



Change the sensor harness



- Unplug the sensor connector from the electronic board
- Remove the two sensors placed on the motors



- Remove the two sensors near the electronic board and the bypass or opposite side of the board if left-hand version.
- Insert the new sensors and plug in the connector



Step No. 9



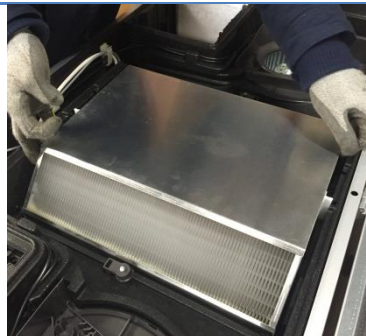



Remove the heat exchanger



- Turn the moving heat exchanger fastenings a quarter of a turn
- Extract the heat exchanger from its housing

Step No. 10	
	<i>Clean the heat exchanger</i>
	<p>-</p> <ul style="list-style-type: none"> - Remove the impurities in the heat exchanger (cleaning with air advised)

Step No. 11	
	<i>Control core replacement</i>
	 <ul style="list-style-type: none"> - Remove the two foam pads on the inside of the door to access the fastening screws. - Unclip the connector from the core using a screwdriver - Reverse the steps to refit it

Step No. 12		
	<p><i>Flash the control board with new software</i></p>	
	<p>- Plug in the USB key containing the new running software</p>	
<p>PREMIUM VERSION</p>	<div style="display: flex; align-items: center; justify-content: center;"> <div style="border: 1px solid black; padding: 5px; margin-right: 20px;"> <p>USB</p> <p>Updating</p> <p>Setting</p> <p>Data History</p> <p>Remove USB...</p> </div>  </div>	<p>- When the core displays "USB", select "UPDATING" and press the ✓ key</p> <p>- When the keypad displays "EJT" you can safely remove the USB key</p>
<p>CLASSIC/MODBUS VERSION</p>		<p>- When the keypad displays "FLS", press the ✓ key, then select "SET" followed by "Par".</p> <p>- When the keypad displays "EJT" you can safely remove the USB key</p>

CAUTION For the PREMIUM versions: repeat step 12 twice (once for the .bin file and once for the .res file). The product launches the correct file automatically each time.

5.4 List of preventive maintenance operations InspirAir 150

P-101			
		Filter replacement	
Filters	Nbr.: 3(+)	Frequency: every nine months	5min.
List of steps: - Step 5			

P-201			
		Cleaning the heat exchanger	
Heat exchanger	Nbr.: : 1	Frequency: every two years	1h
List of steps: - Step 1; 2; 3; 4; 10; 11			

5.5 List of curative maintenance operations InspirAir 150

C-201			
		Motor replacement	
Motor	Nbr.: 1	Standard tools	45min.
List of steps: - Step 1; 2; 3; 4 (depending on motor to be changed); 6			

C-202			
		Electronic replacement board	
Elec. board	Nbr.: 1	Standard tools	45min .
List of steps: - Step 1; 2; 3; 7			

C-203			
		By-pass replacement	
By- pass	Nbr.: 1	Standard tools	45min.
List of steps: - Step 1; 2; 3; 8			



C-204			
		Sensor replacement	
Sensors	Nbr.: 1	Standard tools	45min .
List of steps: - Step 1; 2; 3; 4; 9			

C-205			
		Core replacement	
Core	Nbr.: 1	Standard tools	30min.
List of steps: - Step 1; 2; 3; 12			



C-206			
		Reflash the regulator	
-	-	Standard tools and USB key + software	30min
List of steps: - Step 13			

C-207			
		User keypad replacement (Classic version)	
Core	Nbr.: 1	Standard tools	30min.
List of steps: - Step 1; 2; 3; 14			

5.6 Operating procedures Inspirair 150

	Step No. 1	
<i>Switch the unit off</i>		
		<ul style="list-style-type: none"> - Switch the unit off using the electrical cabinet circuit breaker.

	Step No. 2	
<i>Open the door</i>		
		<ul style="list-style-type: none"> - Remove the filter plugs - Remove the two fastening screws on the door giving access to the equipment's internal components

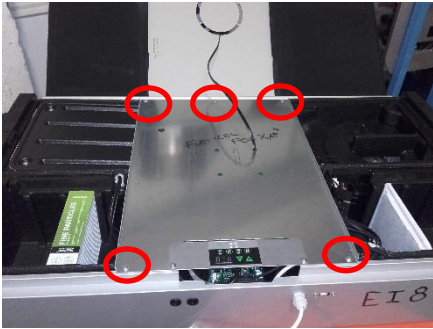
	Step No. 3	
<i>Remove the central plate</i>		
		<ul style="list-style-type: none"> - Remove the two electronic board support screws - Remove the five central plate holding screws

Step No. 4



Remove the condensate tray

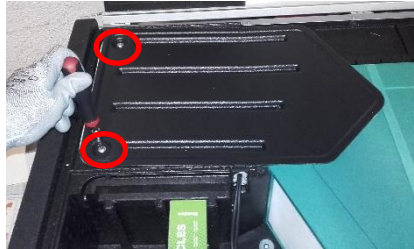
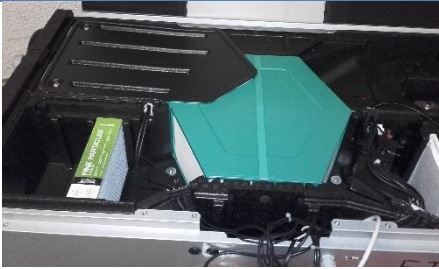

- Remove the central plate in advance (step 3)
- Loosen the two screws

Step No. 5



Change the filters (right-hand version here)



- Open the access hatches to the filters and electronic box
- Remove the filters



- Insert the new filters
- Watch out for the fitting direction for the pollen filters: the arrow must point in the same direction as the one of the box fan

Step No. 6



Replace a motor

⚠ Caution: the two motors are different.



- Remove the cover from the housing

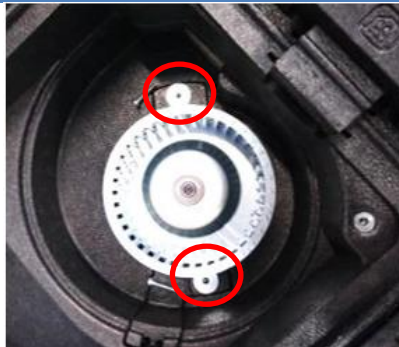
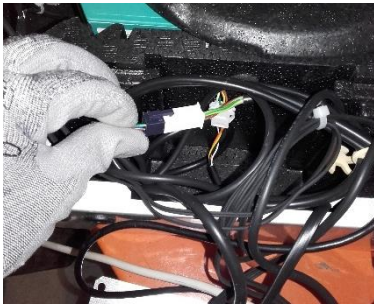

- Unplug the motor connections (extensions on the electronic board)

- Remove the two screws + washers fixed to the PPE body to remove the motor sub-assembly



- Remove the two screws fastening the motor to the metal plate



- Carefully remove the motor

- Insert the new motor and reverse the steps to refit it (caution, make sure you thread the motor cables properly into the grooves)

- carefully tighten the two screws + washers to avoid damaging the PPE)

Step No. 7



Replace the electronic board



- Unplug all connectors from the board

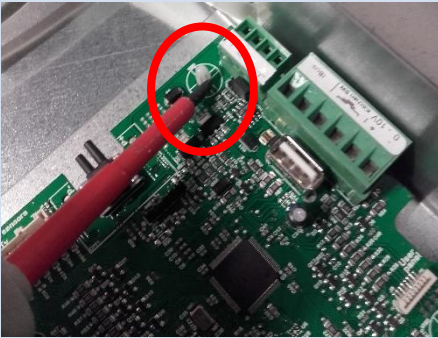

- Press the notches (using a flat screwdriver) to unclip the board from the support

- Fix the new board

- Plug the connectors back in following the drawing in paragraph 4

Step No. 8



Replace the by-pass (thermal cylinder)

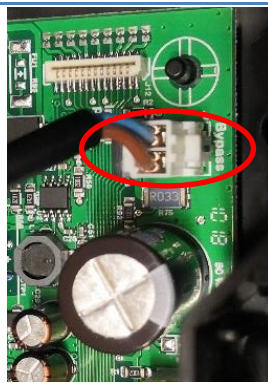
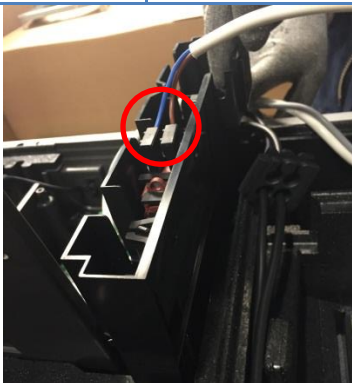

- Unplug the thermal cylinder connections

- Remove the cylinder carefully from its housing

- Insert the new cylinder and plug in the connections

Step No. 9



Change the sensor harness



- Unplug the sensor connector from the electronic board
- Remove the blue (Discharge) and yellow (Fresh air, filter side) sensors

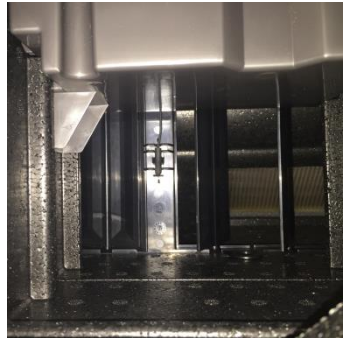

- Remove the two sensors from the other side, red (Air supply) and green (recovery, at the By-pass)
- Insert the new sensors and plug in the connector



Step No. 10



Remove the heat exchanger



- Extract the heat exchanger from its housing

Step No. 11		
	<i>Clean the heat exchanger</i>	
	-	<ul style="list-style-type: none"> - Remove the impurities in the heat exchanger (cleaning with air advised)

Step No. 12		
	<i>Control core replacement</i>	
		<ul style="list-style-type: none"> - Remove the fastening screws - Unclip the connector from the core - Reverse the steps to refit it

Step No. 13



Flash the control board with new software



-

- Plug in the USB key containing the new running software

PREMIUM VERSION



- When the core displays "USB", select "UPDATING" and press the ✓ key

- When the keypad displays "EJT" you can safely remove the USB key

CLASSIC/MODBUS VERSION

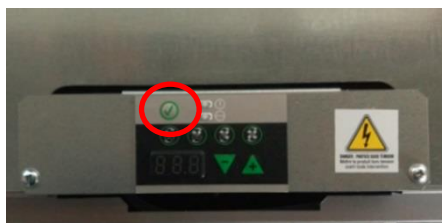

- Select "FLS" by pressing the +/- keys, confirm with the ✓ key, select "SET" and then "Par".

- When the keypad displays "End" you can safely remove the USB key

CAUTION For the PREMIUM versions: repeat step 12 twice (once for the .bin file and once for the .res file). The product launches the correct file automatically each time.

Step No. 14



User keypad change (Classic version)

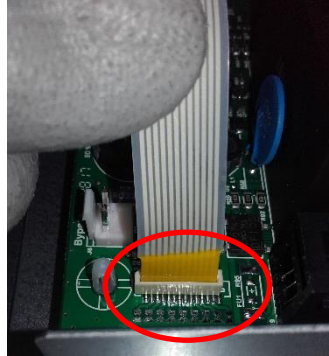

- Remove the electronic board from its location
- Disconnect the board's plug



- Peel the keypad off carefully
- Insert the new screen and reverse the steps to install it

5.7 Repair guide

Please refer to the relevant user manuals for handling the user keypad or control core.
Code to access Expert level on the control core: 0405

List of error codes:

Code	Meaning	Solution
182	Exhaust motor-fan connection unplugged or motor out of service	- Refer to the breakdown flow chart on page 21 for alarm 182
183	Supply motor-fan connection unplugged or motor out of service	- Switch off the power for 30 min., then switch back on - Check the motor wiring - Refer to the breakdown flow chart on page 20 for alarm 183
239	Air exhaust Tr sensor fault	- Check the sensor position - Check the sensor ohm coherence - Refer to the breakdown flow chart on page 22
240	Outside Te sensor fault	
241	Air supply Ti sensor fault	
251	CMEV temperature sensor Tv sensor	
81	Lack of BCA detected	- Refer to the breakdown flow chart on page 18 for alarm 81.
82	MVE and MVI stopped as air supply Ti too low	- Check the BCA Bus port wiring - Check the supply sensor ohm coherence (below) - Refer to the breakdown flow chart on page 19 for alarm 82.

Test values

T: 0° R: 32.7 K Ω T: 15° R: 15.7 K Ω
T: 5° R: 25.4 K Ω T: 20° R: 12.5 K Ω
T: 10° R: 19.9 K Ω T: 25° R: 10.00 K Ω

5.5 Breakdown flow chart



Alarm 81 - The unit does not recognise the BCA

Problems:

- BUS wiring
- Incorrect power supply

Alarm 81 ⇒ Phi safety and lack of BCA

Is the wiring on the BCA Bus port correct?

No → Make compliant



Yes → Check the BCA supply

If alarm still present

Supply sensor ohm coherence

No → Replace sensor harness

INSPIRAIR 240/370 = Step 1; 2; 3; 8 of the guide
INSPIRAIR 150 = Step 1; 2; 3; 4; 9 of the guide

Test values :

T : 0° R : 32,7 KΩ T : 15° R : 15,7 KΩ
T : 5° R : 25,4 KΩ T : 20° R : 12,5 KΩ
T : 10° R : 19,9 KΩ T : 25° R : 10,0 KΩ

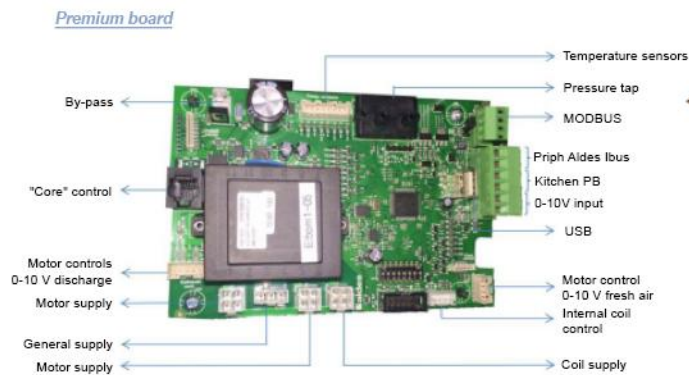

Version	Creation date
V3	AUGUST 2018



INSPIRAIR



Alarm 82 - The exhaust and supply motor-fans are stopped

Problems:

- Dutchwork
- Supply temperature too low
- Incorrect BCA wiring

Alarm 82

Phi safety MVE and MVI stopped

Check the ductwork (not plugged, no holes, etc.)

Supply sensor ohm coherence?

Replace sensor harness
INSPIRAIR 240/370 = Step 1; 2; 3; 8 of the guide
INSPIRAIR 150 = Step 1; 2; 3; 4; 9 of the guide

Test values :

T : 0 ° R :32,7 KΩ	T : 15°R : 15.7 KΩ
T : 5° R :25,4 KΩ	T : 20°R : 12,5 KΩ
T : 10°R :19.9 KΩ	T : 25°R : 10.0 KΩ

BCA R present

Fit the BCA R

Check the BCA R supply

Make compliant

Check the BCA R supply

Premium board

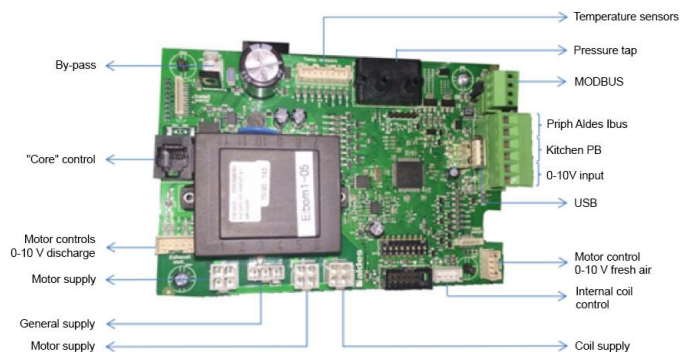

Version	Creation date
V3	AUGUST 2018

INSPIRAIR



Alarm 183 - Supply motor-fan is not working

Problems :

- Motor-fan connection unplugged
- Motor out of service

Alarms 183

Supply motor-fan connection

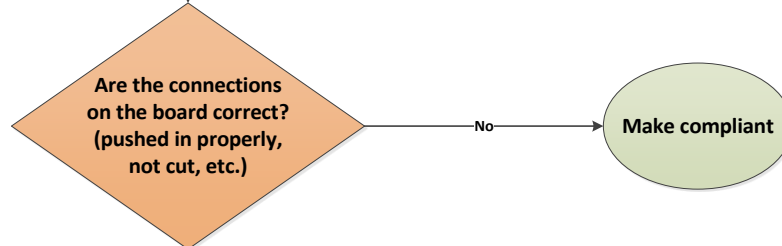

No → **Make compliant**

Yes → **Check the power supply on the board (input and output)**

Output voltage OK → **Replace supply motor**
INSPIRAIR 240/370 = Step 1;2;3;5 of the guide
INSPIRAIR 150 = Step 1;2;3;4;6 of the guide

Output voltage not OK → **Replace electronic board**
INSPIRAIR 240/370 = Step 1;2;3;5 of the guide
INSPIRAIR 150 = Step 1;2;3;7 of the guide

ECO board:

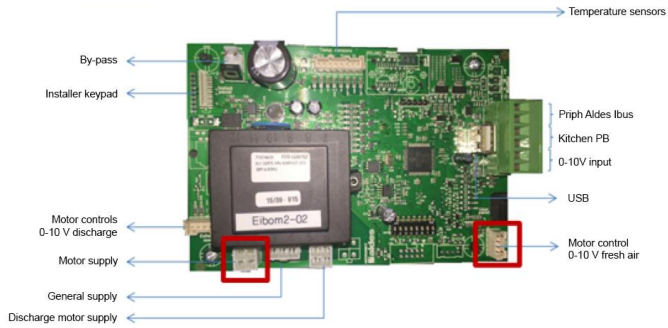

Version	Creation date
V3	AUGUST 2018

INSPIRAIR

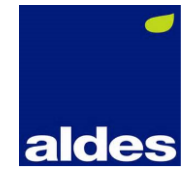

Alarm 182 - Exhaust motor-fan is not working

Problems:

- Motor-fan connection unplugged
- Motor out of service

Alarms 182

Exhaust motor-fan connection

Are the connections on the board correct? (pushed in properly, not cut, etc.)

Make compliant

Check the power supply on the board (input and output)

Replace exhaust motor
INSPIRAIR 240/370 = Etape 1;2;3;5 du guide
INSPIRAIR 150 = 1;2;3;4;6 du guide

Replace electronic board
INSPIRAIR 240/370 = Step 1;2;3;5 of the guide
INSPIRAIR 150 = Step 1;2;3;7 of the guide

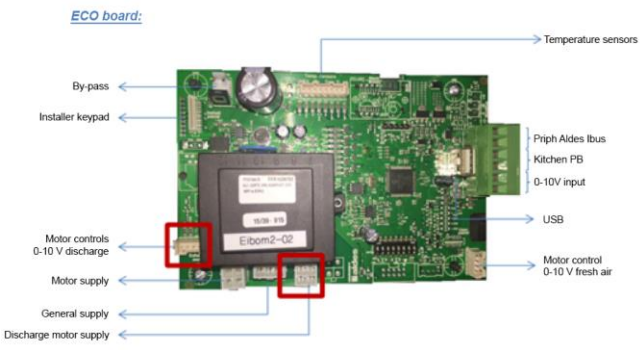

Version	Creation date
V3	AUGUST 2018

INSPIRAIR



Alarms 239, 240 241 and 251 - One or more sensors no longer working

Problems:

- Incorrect position or incorrect wiring
- Sensor out of service

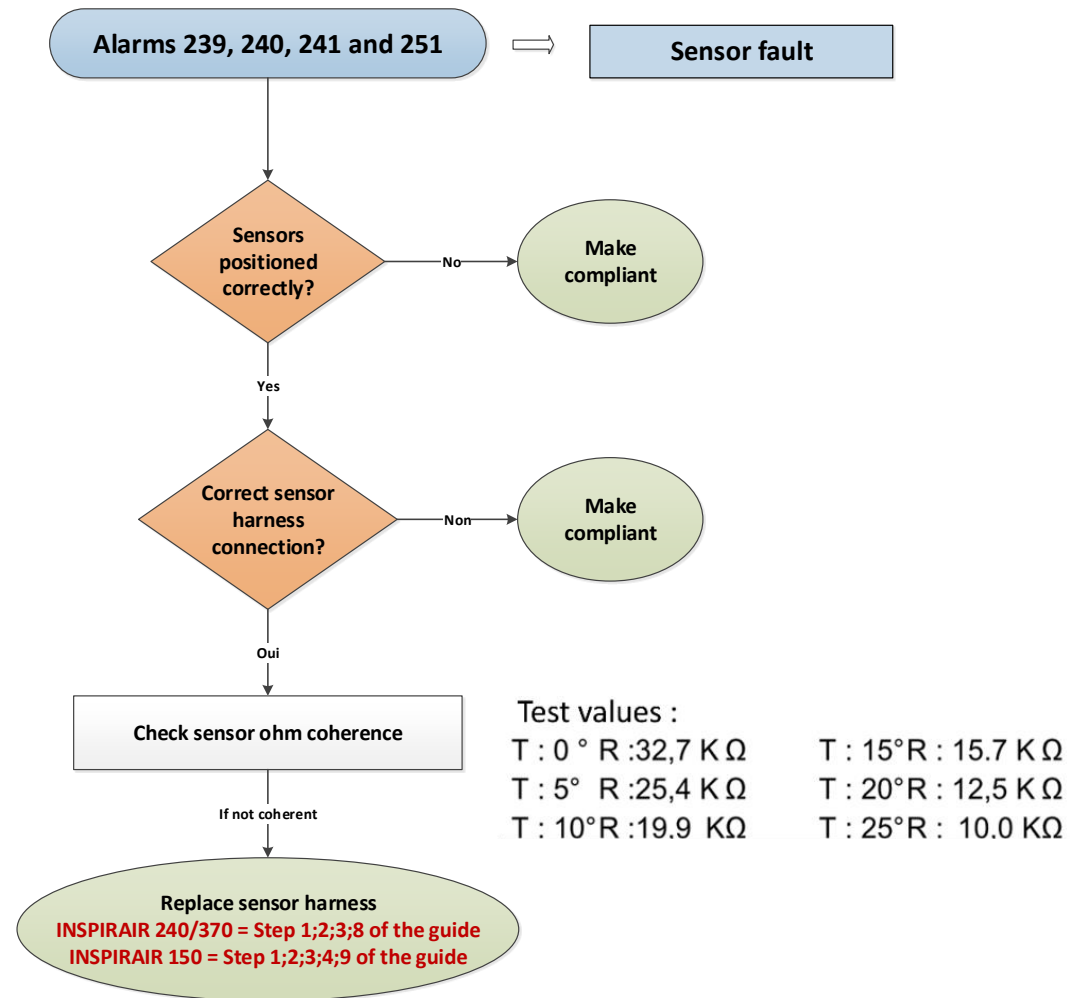

Version	Creation date
V3	AUGUST 2018

INSPIRAIR



The measured airflow is less than the setpoint airflow

Problems:

- Electronic board
- Leaking ductwork
- Incorrect type of terminal



Incoherence between setpoint and measurement

Check the state of the ductwork (not leaking, connected properly, not plugged)
Check the connection and cleanliness of clear tubes on the board



Premium board:

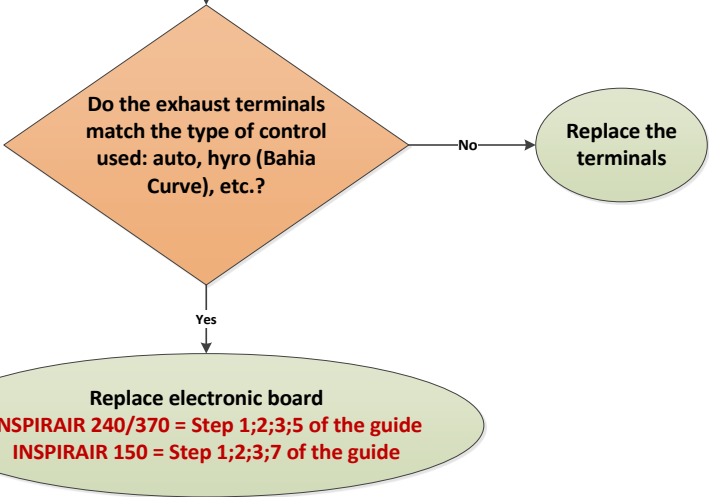
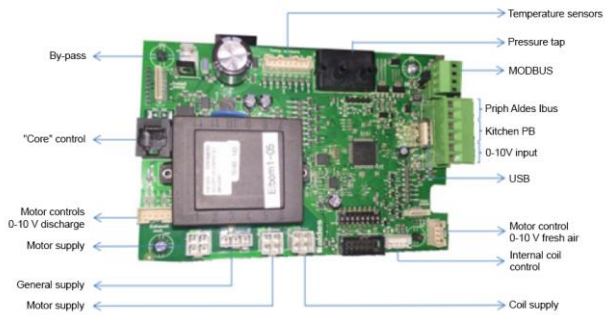

Version	Creation date
V3	AUGUST 2018

INSPIRAIR



Since 10/2016, the door hinges have been moved by 1,5 mm
Problems:
 - Impossible to fit current door to pre-October 2016 version

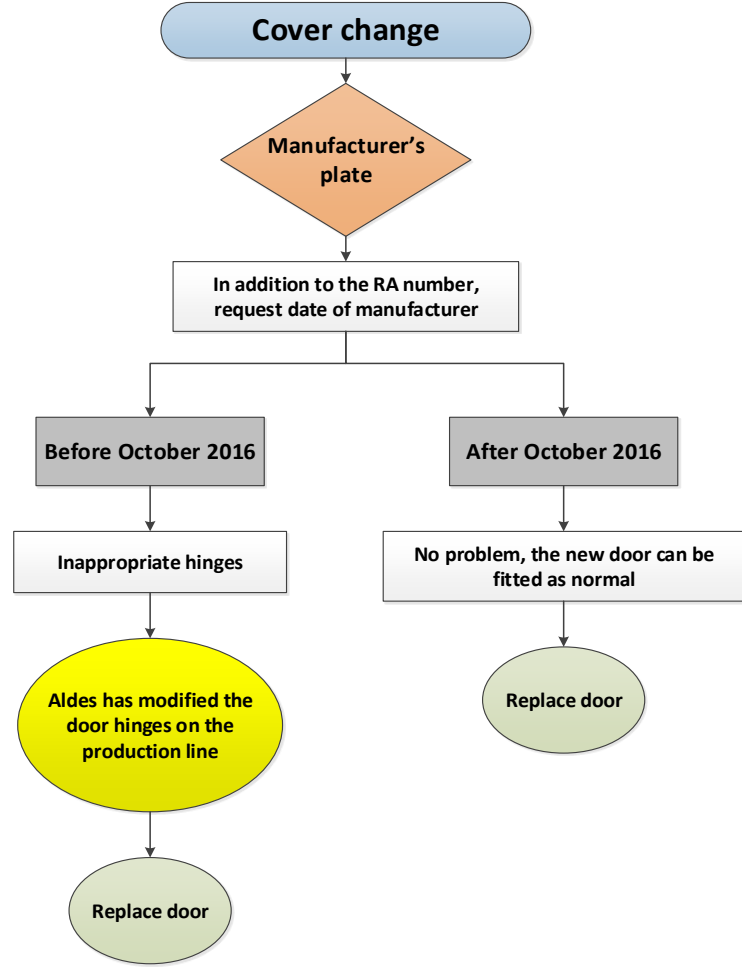

Version	Creation date
V2	January 2018

INSPIRAIR



White bar on the unit core – Step 1,2; 11 of the intervention guide

Problems:

- Incorrect connection with the RJ connectors or RJ out of service
- Electronic board out of service or loss of SOFTWARE



Core problem

Is the connection with the RJ connectors correct (board side and core side)?
Are the connectors compliant?

No → Make compliant, replace the RJ

Yes

SOFTWARE updated
INSPIRAIR 240/370 = Step 12 of the guide
INSPIRAIR 150 = Step 13 of the guide

Is the core working?

Non

Replace electronic board
INSPIRAIR 240/370 = Step 1;2;3;5 of the guide
INSPIRAIR 150 = Step 1;2;3;7 of the guide

Yes

End of procedure

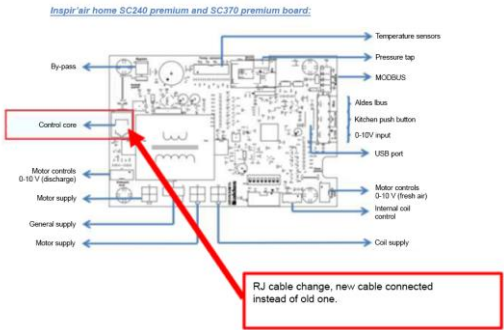

Version	Creation date
V4	JANUARY 2019

INSPIRAIR

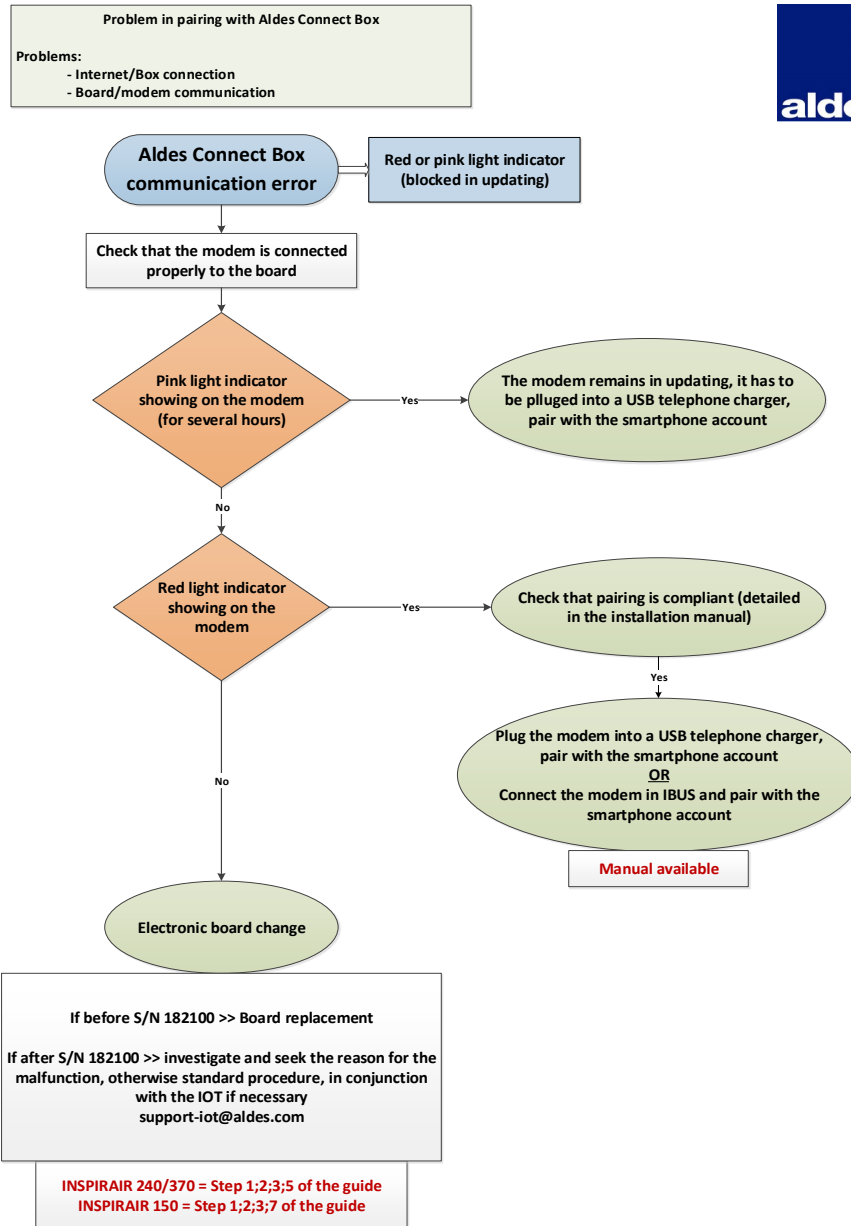

Version	Creation date
V3	AUGUST 2018